

## Manure Spreader Calibration for Rear-discharge Equipment

### Handling Solid and Semi-solid Manures and Poultry Litter

*Lori Marsh, Extension engineer and associate professor, Department of Biological Systems Engineering, Virginia Tech*  
*Greg Mullins, Extension agronomist and professor, Department of Crop and Soil Environmental Sciences, Virginia Tech*  
*Scott Ambler, poultry waste coordinator, Virginia Department of Conservation and Recreation*  
*Rick Heidel, Extension Agriculture and Natural Resources agent, animal science, Augusta County, Virginia*

To maximize crop productivity and minimize adverse environmental effects, it is critical that land applications of manures meet, but not exceed, crop nutrient requirements. To assure that the actual manure application rate matches the desired application rate, manure-spreading equipment must be calibrated. The goal of manure spreader calibration is to determine the amount of manure, on a weight per unit area basis, that is being applied to a field. This publication describes three methods for manure spreader calibration for spreaders handling solid and semi-solid manures.

#### What does calibration involve?

The application rate is a function of gear and throttle settings, which determine PTO (power take off) speed and ground speed; spreader equipment settings; and the amount of overlap due to width between passes in the field. A separate but related issue is the uniformity of the manure application.

#### How often should the equipment be calibrated?

It is a good idea to calibrate your manure application equipment before spreading any large volume of manure. The required calibration schedule for confined animal feeding operations holding a Virginia Pollution Abatement (VPA) permit for poultry or livestock is specified within the operation's nutrient management plan. Typically, a nutrient management plan specifies

calibration before major cleanouts and/or at least twice a year. For manure spreaders handling solid materials, you should do calibration whenever the consistency of the manure is obviously different from the last batch used for calibration. Possible causes for changes in manure consistency include changing the bedding material, changing feed ingredients, or any change in the production system that affects the moisture content of the manure.

Manure spreader calibration results should be a permanent part of every farm's records for crop nutrient application. Regulated producers are required by their permits to keep written records of their spreader calibrations for at least five years.

#### What calibration methods are available?

Three strategies are suggested for manure spreader calibration:

1. **Tarp Method:** Spreading manure onto tarps of known area and weighing the tarps.
2. **Load-area Method One:** Spreading a load of manure of known weight and measuring the ground area covered; and
3. **Load-area Method Two:** Spreading enough loads of known weights to cover a known area.

The tarp method has the advantage of providing information about the uniformity of the manure application and

helps you determine the appropriate overlap between application passes. The load-area methods (methods 2 and 3) are easier and more accurate at determining application rates, but do not provide any information regarding the uniformity of spreading. Therefore, you should use the tarp method at least once to determine the correct overlap distance and the settings required for a uniform distribution. Once the overlap distance and settings for uniform distribution are determined, using either of the load-area methods, which involve a greater area of spread, will provide a more accurate determination of the application rate.

Both of the load-area methods require that you know the weight of manure in a spreader load. The user's manual for your manure spreader specifies the load capacity of the spreader on a volume basis. Unfortunately, it is difficult to accurately convert from manure volume to manure weight for solid and semi-solid manure, because the conversion depends upon how the manure is packed into the spreader. The denser the packing, the more weight the same volume will hold.

The most accurate way to determine the weight of a load of manure in a spreader is to weigh the spreader both empty and full and then subtract the empty weight from the full weight to arrive at the weight of the manure. The regional watershed offices of the Virginia Department of Conservation and Recreation (listed at the end of this publication) have portable scales that you can use for this task. Contact them to arrange to borrow the scales. While the offices are willing to loan out the scales, you must plan ahead. Do not wait until the day before you plan to spread manure to contact them to schedule the use of their scales.

If you have access to scales capable of weighting your spreader, the load-area methods are recommended for calibrating the application rate. **Load-area Method One** requires that you spread enough loads (a minimum of one) to cover approximately one acre and then measure the area covered. **Load-area Method Two** involves spreading a field of known area (it should be less than five acres), and tracking the total weight of manure applied.

If you do not have access to large scales, you can use the tarp method, which only requires small scales capable of weighting a bucket and a manure-laden tarp.

## What determines the manure application rate from a spreader?

The rate at which manure is applied depends on several things:

1. Equipment ground speed. All other things being equal, the faster you go, the greater the area that will be covered by the same weight of manure, so the application rate is lower.
2. The PTO speed. The faster the PTO spins, the more manure will be ejected from the spreader.
3. The settings on the spreader. The spreader settings depend on the specific equipment, but typically you can adjust the following:
  - a. For Spreader Trucks:
    - i. The gate setting
    - ii. The chain speed
    - iii. The spinner speed. Spinner speed primarily affects the uniformity of distribution, but it also affects the width of the swath covered, thereby affecting application rate.
  - b. For Box Spreaders:
    - i. The drag or push speed
    - ii. The flail or beater speed
    - iii. The pan location relative to the flails. The pan location also affects the distribution pattern.

For all the calibration methods described, you should record the gear setting, throttle setting (or tachometer reading), and spreader equipment settings at which you apply the manure. The calibration procedure should be repeated at different spreader settings or tractor gear/tachometer settings until you achieve the desired application rate. By keeping records of the tractor and spreader settings for each calibration run, you will be able to reproduce the conditions and thus the application rates that you achieved during calibration.

## Tarp Method

This method requires a small scale capable of weighing a bucket containing manure and tarps that have received a manure application. The following steps are required to use this method:

1. Acquire five tarps that are the same size—ones 10 ft x 10 ft or 12 ft x 12 ft work well. Alternatively, cut five sheets of polyethylene. Note: a commercial tarp that is labeled 10x10 will actually be smaller because the size listed is before they turn down the sides and insert grommets. Therefore, it is best to actually measure the tarps you intend to use. It is easier to keep track of each tarp if you number each one. Record the length and width of each tarp on the correct line of Worksheet 1 in columns B and C.
2. Find the area of each tarp (column B x column C) and record it on the correct line of Worksheet 1 in column D.
3. Weigh each tarp and record its weight on the correct line in column E.
4. Weigh an empty five-gallon bucket. Record its weight on Worksheet 1 in column F.
5. Locate a large and reasonably smooth, flat area where the manure can be applied. The area must be firm, since the vehicle tires will be traveling directly over the tarp. Soft ground will cause the tarp area to be severely distorted. Spread the tarps on the ground in a line (see Figure 1) and secure them at each corner using a wire flag or stone. The distance between the centerline of tarp 1 and tarp 3 (see Figure 1) should be the distance that you usually place between passes when spreading manure. Similarly, the distance between the centerline of tarp 3 and tarp 5 should be your typical pass width. Place tarp 2 so that it is centered between tarps 1 and 3 and place tarp 4 so that it is centered between tarps 3 and 5 (Figure 1). Place a flag on the centerlines of tarps 1, 3, and 5.
6. Start spreading a load of manure sufficiently before the tarps (at least 50 feet) so that you are traveling at a representative ground speed when you reach them. Continue spreading, so that the center of the tractor passes directly over the centerline of tarp 1. Continue spreading beyond the tarps so that you can turn and pass over the centerline of tarp 3 while

traveling at a representative ground speed. After spreading over tarp 3, turn and spread over the centerline of tarp 5.

7. Fold the sheets to collect the manure that fell on them.
8. Keeping track of the location that a tarp came from (1 through 5) place a folded tarp, with manure, into the five gallon bucket and weigh the bucket with the tarp in it. Record the weight of bucket with manure-covered tarp on Worksheet 1 in on the correct line column H. Remove the manure-laden tarp from the bucket.
9. Repeat step 7 until all tarps have been weighed.
10. Subtract the Tarp + Bucket weight for each tarp from the Manure + Tarp + Bucket weight (column G - column H) to get the weight of the manure in each tarp. Record the weight on Worksheet 1 in column I on the corresponding line.
11. Complete the calculations in Worksheet 1 to determine the application rate.

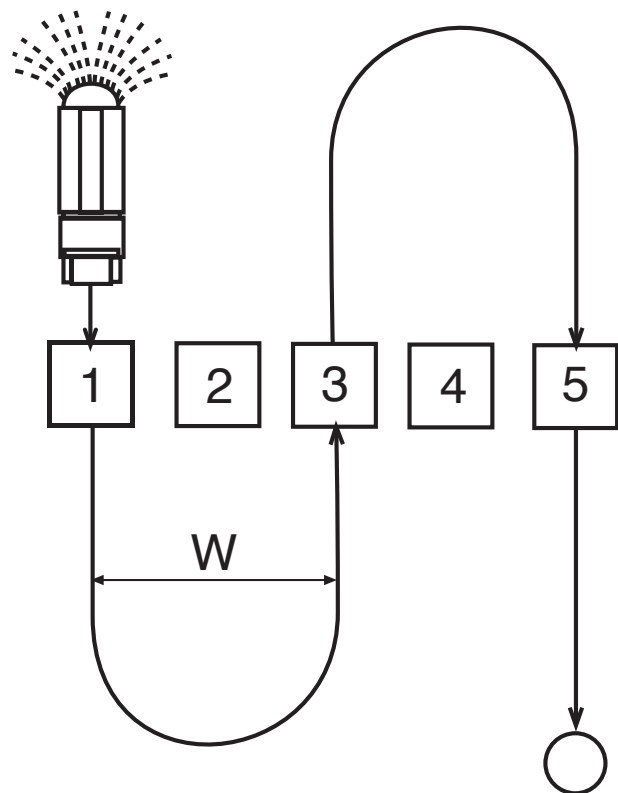

**Figure 1.** Location of tarps for determining uniformity of manure distribution. Note: W is the width between passes when spreading.

# Worksheet 1: Spreader Calibration by the Tarp Method.

1. Ground speed and gear/throttle setting: \_\_\_\_\_
2. Equipment settings (gate opening, spinner, chain, etc): \_\_\_\_\_

A	B	C	D	E	F	G	H	I
Item (ft)*	Tarp Length (ft)*	Tarp Width (col B x col C)	Tarp Area (ft <sup>2</sup> ) (lb)	Tarp Weight (lb)	Bucket Weight (col E + col F)	Tarp + Bucket Weight (lb)	Manure + Tarp + Bucket Actual Scale Weight (col H - col G)	Manure Weight (lb)
Tarp 1								
Tarp 2								
Tarp 3								
Tarp 4								
Tarp 5								
<b>Total</b>								

\* Note: If the sheet was not an even increment of feet, divide the inches by 12 and add to the feet. For example, a sheet 8'4" would be 8 + 4/12 = 8.33 ft.

3. Determine the application rate:

$$\text{Application rate} = \frac{\text{Total Column I (lbs)}}{\text{Total Column D (ft}^2\text{)}} \times \frac{1 \text{ ton}}{2000 \text{ lbs}} \times \frac{43560 \text{ ft}^2}{1 \text{ acre}} = \frac{\text{Total Column I (lbs)}}{\text{Total Column D (ft}^2\text{)}} \times 21.8 = \underline{\hspace{2cm}}$$

Example: A poultry producer collects a total of 78 lb of litter on 5 tarps. Each tarp is 10 ft long and 10 ft wide. Total tarp area = 10 ft x 10 ft x 5 tarps = 500 ft<sup>2</sup>

$$\text{Application rate} = \frac{78 \text{ lb}}{500 \text{ ft}^2} \times \frac{1 \text{ ton}}{2000 \text{ lbs}} \times \frac{43560 \text{ ft}^2}{1 \text{ acre}} = \frac{78 \text{ lb}}{500 \text{ ft}^2} \times 21.8 = 3.4 \text{ tons/acre}$$

## Checking for Uniformity of Distribution

To determine the uniformity of the manure application, compare the weight of manure collected on each of the five tarps. If the weights of manure on all five tarps are reasonably close, no adjustment is needed in uniformity and you should continue to the calibration calculations.

**For Spreader Trucks:** If tarps 1, 3, and 5 are heavier than tarps 2 and 4, the manure may not be contacting the spinners at the correct location resulting in too MUCH material landing directly behind the spreader. The chute may need to be moved away from the truck (See figure 2) or the gate setting/drag chain speed may be feeding too much material for the spinners to handle.

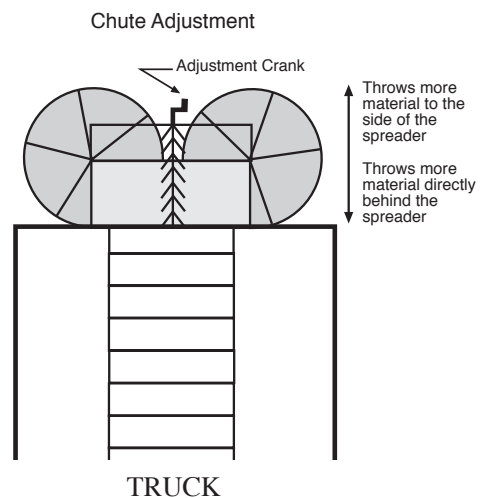

Figure 2. Adjustments for a spreader truck with spinner.

If tarps 2 and 4 are heavier than tarps 1, 3, and 5, the manure may not be contacting the spinners at the correct location resulting in too little material landing directly behind the spreader. The chute may need to be moved toward the truck (See Figure 2) or the width between passes may need to be increased (too much overlap).

If tarps 2 and 4 are not reasonably close in weight, the chute and divider are not supplying litter to the spinners at equal rates and the chute needs adjustment.

For Box Spreaders: If tarps 2 and 4 are heavier than tarps 1, 3, and 5, then there is too much overlap and the width between passes should be increased. If tarps 2 and 4 are lighter than tarps 1, 3, and 5, then there is not enough overlap and the width between passes should be decreased.

The load-area method should be repeated until a reasonably uniform application is achieved. After uniformity is achieved, you can use the data collected to determine the application rate.

## Determining the Application Rate

The application rate is the total weight of manure collected on the tarps divided by the collection area and multiplied by a constant to convert lb/ft<sup>2</sup> to ton/acre (see Application rate below).

While it is possible to determine the application rate from the tarp method, it is less accurate than either of the load-area methods. Once uniformity of application has been established, it is best to determine the application rate using one of the two load-area methods.

### Load-area Method One:

Note: Worksheet 2 is provided for recording data and making the necessary calculations.

1. To determine the weight capacity of your spreader, load it, making note of how full it is so that you can load the same amount for all the loads used during calibration. Next, weigh the full spreader and tractor and record the weight on Worksheet 2 in column B.
2. Spread the manure/litter on a selected field. Choose a spreader path spacing to achieve uniform coverage. Spread in a rectangle or square so it will be easy to calculate the area covered.

3. After the load has been spread, reweigh the tractor and empty spreader, recording the empty weight on Worksheet 2 in column C. The difference in weight full and empty represents the weight of manure in the load.
4. Repeat steps 1 through 3 until at least one-half acre of ground has been covered. Maintain the same ground speed, throttle setting (or tachometer setting) and spreader setting for each load. After at least one-half acre has been spread, measure the area covered. To do this, mark the corners of the area that was spread using flags or stakes and then measure the length and width of the plot with a measuring tape or a measuring wheel.
5. Perform the calculations shown on Worksheet 2.
6. If the application rate was not what you needed, or more than one application rate is needed for different fields, then change the setting on the spreader or change the gear/throttle setting and repeat the calibration process, using a new worksheet.

### Load-area Method Two

Note: Worksheet 2 is provided for recording data and making the necessary calculations.

1. Spread manure on the field of known area, taking care to achieve as uniform a distribution as possible. Weigh the spreader full, before spreading and record the weight on the correct line of Worksheet 2 in column B.
2. Weigh the spreader empty after the load is spread and record the weight on the correction line in column C.
3. Record the weight of each load on the correct line of Worksheet 2 in column D (column B - column C).
4. Continue spreading until the field is covered, keeping track of the number of loads used. This is done by recording the weight of each load as specified in steps 1 through 3 above.
5. Perform the calculations on Worksheet 2 to determine the application rate.
6. If the application rate is not what you needed, or more than one application rate is needed, then change the setting on the spreader or change the gear/throttle setting and repeat the calibration process using a new Worksheet 2.

This method of spreader calibration, based upon spreading a field of known size, requires the least effort. However, it has the distinct disadvantage of determining the application rate AFTER THE FIELD IS SPREAD. For a small field, this is not really a problem, but you should not use this method on a field larger than five acres. Another disadvantage of this method is that repeated tests to determine application rates at different tractor and spreader settings require additional fields of known size.

## Acknowledgements

The authors would like to express their appreciation for the review and comments made by Bobby Clark, Virginia Cooperative Extension agent, Warren County; and Susan Gay, assistant professor and Extension engineer, and Bobby Grisso, professor and Extension engineer, both of the Department of Biological Systems Engineering, Virginia Tech.

## Worksheet 2: Spreader Calibration Using the Load-area Method

1. Ground speed and gear/throttle setting: \_\_\_\_\_
2. Equipment settings (gate opening, spinner, chain, etc): \_\_\_\_\_
3. Weight Data from spreading: \_\_\_\_\_

A	B	C	D
Load #*	Weight of Equipment with Manure	Weight of Equipment Empty	Weight of Manure (column B - column C)
1			
2			
3			
4			
5			

Sum of Column C (total weight of manure applied) =

*\* If you are applying to a known area, apply as many loads as needed to cover the area.*

4a. If the area is unknown, measure the area covered: Length of area \_\_\_\_\_ ft Width of area \_\_\_\_\_ ft  
 Area = length (ft) x width (ft)/43,560 = \_\_\_\_\_ acres

Or

4b. If the area is known, record the area = \_\_\_\_\_ acres

5. Determine the amount of manure applied:

- a. Sum all the weights in Column C of the data table = \_\_\_\_\_ lbs.
- b. If the weight was measured in pounds, convert to tons:  
 Weight in lbs/2,000 = \_\_\_\_\_ tons.

6. Determine the application rate:

Amount applied (line 5 b)/Area covered (line 4a or 4b) = \_\_\_\_\_ tons/acre

## Contact Information

If you have questions regarding manure spreader calibration, contact your local Virginia Cooperative Extension agent (listed in the phone book under County Government) or your local Department of Conservation and Recreation representative, as shown below:

### DCR's regional offices

**Abingdon** (Tennessee-Big Sandy Watersheds Office): 252 W. Main Street Suite 3, Abingdon, VA 24210; phone: (276) 676-5528, fax: (276) 676-5527

**Chase City** (Roanoke Watershed Office): 411 Boyd Street, Chase City, VA 23924; phone: (434) 372-2191, fax: (434) 372-4962

**Dublin** (New River Watershed Office): PO Box 1506, Dublin, VA 24084; phone: (540) 643-2590, fax: (540) 643-2597

**Fredericksburg** (Rappahannock Watershed Office): 2601 Princess Anne St., Suite 101, Fredericksburg, VA 22401; phone (540) 899-4463; fax: (540) 899-4389

**Henrico** (James River Watershed Office): 3800 Stillman Pkwy., Suite 102, Richmond, VA 23233; phone (804) 527-4484, fax: (804) 527-4483

**Staunton** (Shenandoah Watershed Office): 44 Sanger Lane, Suite 102, Staunton, VA 24401; phone: (540) 332-9991, fax: (540) 332-8956

**Suffolk** (Chowan-Albemarle Coastal Watersheds Office): 1548 Holland Road, Suffolk, VA 23434; phone: (757) 925-2468, fax: (757) 925-2388

**Tappahannock** (York Watershed Office): PO Box 1425, Tappahannock, VA 22560; phone: (804) 443-6752, fax: (804) 443-4534

**Warrenton** (Potomac Watershed Office): 98 Alexandria Pike Suite 33, Warrenton, VA 20186-2849; phone: (540) 347-6420, fax: (540) 347-6423



*Reviewed by Jactone Arogo, Extension specialist, Biological Systems Engineering*